

Parco O-Ring Size Chart

An O-ring is a solid-rubber seal shaped like a doughnut or torus. When compressed between mating surfaces, an O-ring blocks the passage of liquids or gases. Parco O-rings are available in a wide range of standard and non-standard sizes that are suitable for nearly all sealing applications.

Two dimensions describe the size of an O-ring: its inside diameter (ID) and its cross-sectional diameter (CS) (see Figure 1).

Understanding O-ring Sizes and Tolerances

Standard Sizes

The standard sizes used by Parco and the other major O-ring manufacturers in the United States are defined by Aerospace Standard AS568B, *Aerospace Size Standard for O-rings*. That document, published by the Society of Automotive Engineers (SAE), lists the sizes of O-rings in six series or groups in both inches and millimeters. The first five series are based on cross-sectional diameter. The sixth series includes 20 sizes for boss seals. The standard sizes are also used for most military specifications.

Cross-sectional diameters range from 0.040 to 0.275 inch. Inside diameters range from 0.029 to 25.940 inches. Parco also has hundreds of molds for non-standard sizes. Parco offers O-rings in all 369 standard sizes, shown on the enclosed chart.

Metric Sizes

Standard metric sizes for O-rings are defined by International Standard ISO 3601-1:2002: *Fluid power systems O-rings Part 1: Inside diameters, cross-sections, tolerances and size identification code*. That standard groups metric sizes into two series, G and A.

The G series is used for general purpose applications and includes a wide range of inside diameters. The A series is used for aerospace applications where tighter tolerances are recommended. The G series has 445 sizes and the the A series has 383 sizes.

The International Organization for Standardization issued ISO 3601-1 in 1978 and revised it in 1988 and 2002. Another major revision is being developed to bring ISO sizes in line with the sizes in Aerospace Standard AS568B. Currently, ISO sizes do not use a dash numbering system like the Aerospace Standard. ISO cross-sectional diameters differ from the Aerospace Standard by less than 0.001 inch. Therefore, many AS568B sizes are interchangeable with an ISO size. Be sure to consult ISO 3601-1 for specific dimensions, as inside diameters may differ.

If Parco does not have a mold for a non-standard size or a particular ISO size, we can make one for you.

Dimensional Tolerances

The tolerances of AS568B, introduced in 2001, are a combination of the former Class I and Class II tolerances of AS568. Below is a brief history of that standard.

In 1958, the SAE issued Aerospace Recommended Practice ARP568, *Uniform Dash Numbering System for O-rings*. In 1971, the SAE replaced ARP568 with Aerospace Standard AS568. AS568 called for two classes of tolerances for inside diameters. Class II was for O-rings made of higher-shrinkage elastomers, such as fluorocarbon and fluorosilicone. Class I was for O-rings made of other elastomers. Class II permitted wider tolerances than Class I.

O-ring sealing is based on the volume relationship between the O-ring and the gland. Slightly wider dimensional tolerances, especially for larger diameter O-rings, make no significant difference in the O-ring volume. Therefore, seals made to Class II tolerances have proved as effective as seals made to Class I tolerances.

For that reason, Aerospace Standard AS568A used a single set of tolerances for inside diameters. For O-rings with IDs less than 0.5 inch, AS568A used the former Class I tolerances. For larger O-rings, AS568A used the Class II tolerances. In 2001, AS568B was issued to modernize the scope and notes of the standard without affecting the dimensions, tolerances, or dash numbers.

The tolerances from AS568B are being incorporated into all U.S. military specifications and drawings as they are revised. In the future, we expect most AN, MS, and NAS tolerances to match AS568B. Also, many companies have revised their own standards to match AS568B.

Choosing the Correct Cross-Sectional Diameter

You may choose O-rings from several standard cross-sectional diameters for your application.

For all applications, O-rings with a larger cross-sectional diameter tend to have better resistance to compression set. They also have less volume swell in fluids and are less likely to leak if their surface is scratched. O-rings with smaller cross-sectional diameters have better physical properties, are more resistant to explosive decompression, and require less space.

For many dynamic applications, there is some choice of cross-sectional diameters. Larger cross-sectional diameters are more resistant to rolling in a groove but have more friction. For reciprocating applications, O-rings with small cross-sectional diameters have less friction but tend to slide and roll in a groove. This can lead to leaks caused by spiral failure of the O-ring.

O-rings with smaller cross-sectional diameters have better physical properties, are more resistant to explosive decompression, and require less space.

In general, tighter tolerance components or rigid components with smooth or ground surface finishes can use O-rings with the smallest cross-sectional diameter regardless of the pressure. Parts with looser tolerances or less rigid components, such as large plastic housings, should use O-rings with larger cross-sectional diameters. Those plastic housings could flex under high pressure or expand when heated, reducing the actual squeeze on the seal.

Boss Seals

A boss seal is an O-ring used for sealing a straight-thread tube fitting on a boss. A boss is a cylindrical projection on a casting or forging. The end of that projection is machined to provide a flat, smooth surface for sealing. Straight threads used with an O-ring provide a better seal than tapered threads used alone (see Figure 2).

The 900 series of dash-numbers identifies the 20 sizes of boss seals. Except for size -901, the two digits after the 9 identify the nominal tube size in 16ths of an inch. The tube size is its outside diameter (OD). For example, size -903 is intended for use with 3/16-inch tube. The one exception, size -901, is intended for use with 3/32-inch tube. 1/16-inch tube is not common in hydraulic applications.

Fig. 2

Tube Fitting With Boss Seal

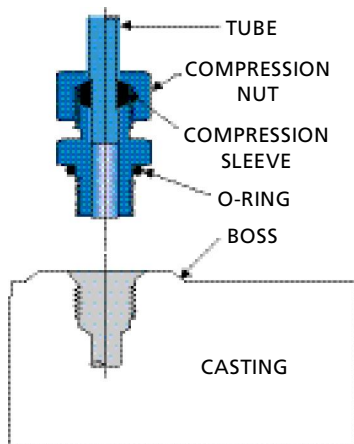

Using the O-Ring Size Chart

To identify which AS568B standard O-ring size is appropriate for your application, you must know the required cross-sectional diameter and either the inside diameter or the outside diameter.

Parco's O-ring size chart is arranged by cross-sectional diameter and then inside diameter. Each combination of cross-sectional diameter and inside diameter has been assigned a unique size (or dash number). Certain O-ring sizes for static seals, reciprocating seals, and rotary seals should be installed in grooves with different diameters.

Ordering Parco O-rings

To order O-rings, please state the Parco part number (size) and Parco compound number. Parco's part numbers for standard-sized O-rings are in the format 0568-xxx. The 0568 refers to Aerospace Standard AS568B. The dash number (-xxx) is the standard O-ring size. Parco compound numbers are in the format xxxx-xx. The first four digits are the basic compound number. The next two digits are the hardness (durometer, Shore A).

For example, you may want to order O-rings with a cross-sectional diameter of 0.139 inch and an inside diameter of 0.984 inch (standard size -214). You may want those O-rings in Parco's popular 70-durometer nitrile compound 4200-70. Please identify those O-rings using Parco part number 0568-214 and Parco compound number 4200-70.

Parco Delivers Faster

Parco can provide sample O-rings within ten working days. If you need sample parts even faster, Parco can deliver them in as few as three days through its Rapid Prototype Program.

For more information on Parco's O-rings or to obtain samples, please contact a Parco customer service representative or one of our distributors.

Parco

Parco, Inc., 1801 S. Archibald Ave., Ontario, California 91761
909-947-2200 Fax 909-923-0288 parcoinc.com